

Publication number : 2002-131762

Date of publication of application : 09.05.2002

-----  
Int.Cl. G02F 1/1339 G02F 1/13 G09F 9/00  
-----

5

Application number : 2000-331179

Applicant : SHINETSU ENGINEERING KK

Date of filing : 30.10.2000

Inventor :

10

ISHIZAKA ICHIRO

MIYASHITA KUNIHIRO  
-----

APPARATUS AND METHOD FOR LAMINATING SUBSTRATES FOR LIQUID  
CRYSTAL PANEL

15

[Abstract]

**PROBLEM TO BE SOLVED:** To align substrates by externally moving substrates in  $XY\theta$  directions outside of pressurizing plates while keeping only the space between the pressurizing plates in a sealed state.

20

**SOLUTION:** The pressurizing plates 1, 2 holding two substrates A, B are moved nearer to each other so as to seal the space between the peripheral edges 1a, 2a of the plates by a movable sealing means 4 to form a section of a closed space S while the substrates A, B are moved nearer to each other to form a specified gap. Then while the air in the closed space S is  
25 evacuated, the pressurizing plates 1, 2 are relatively moved and adjusted in

along  $XY\theta$  directions to roughly align the substrates A, B. After a specified vacuum degree is obtained, the movable sealing means 4 is deformed to move the substrates A, B further nearer to each other the position where the gap between the substrates A, B is sealed with an annular adhesive C. In  
5 this state, the pressurizing plates 1, 2 are relatively moved and adjusted in the  $XY\theta$  directions to finely align the substrates. Then the substrates are released from only one of the plates 1, 2 to return the closed space S to the atmospheric pressure so that the gap is uniformly pressed by the pressure difference between the inside and outside of the substrates A, B to form a  
10 specified gap.

**[Claims]**

**[Claim 1]**

An apparatus for laminating substrates for a liquid crystal panel in which two sheets of substrates A and B which can be freely attached and detached with respect to a pair of upper and lower pressing plates 1 and 2 are folded in a vacuum state, adjusted and moved relatively in XYθ directions by a position determining unit 8 so as to be roughly aligned and precisely aligned, and then, pressed to fill up to a certain gap, comprising: a support means 3 for supporting the substrates A and B installed on the facing surfaces of the both pressing plates 1 and 2 such that they cannot be moved; a movable seal means 4 for supporting freely movement relatively in the XYθ directions in a state that the circumferential portions 1a and 2a facing the both pressing plates 1 and 2 are hermetically closed, and elastically deformed in a vertical direction; a first pressing means 5 for moving the both pressing plates 1 and 2 to approach relatively with each other, forming a closed space (S) such that the both substrates A and B can be surrounded between the both pressing plates 1 and 2, and approaching the both substrates A and B each other up to a certain interval; a suction means 6 for removing air in the closed space (S) to form a vacuum therein; a second pressing means 7 for approaching the both substrates A and B which has been approached by the first pressing means 5 to be closer up to a position where the substrates A and B can be hermetically closed with an annular adhesive (C); and a position determining unit 8 for adjusting and moving the both pressing plates 1 and 2 relatively in the XYθ directions in a state that the first and second pressing means 5 and 7 are operating, and

installed outside the closed space (S).

**[Claim 2]**

A method for laminating substrates for a liquid crystal panel in which  
5 two sheets of substrates A and B which can be freely attached and detached  
with respect to a pair of upper and lower pressing plates 1 and 2 are folded  
in a vacuum state, adjusted and moved relatively in  $XY\theta$  directions by a  
position determining unit 8 so as to be roughly aligned and precisely aligned,  
and then, pressed to fill up to a certain gap, comprising: a step in which the  
10 two sheets of substrates A and B are supported on facing surfaces of the  
both pressing plates 1 and 2 such that they cannot be moved; a step in  
which as the both pressing plates 1 and 2 approach, the facing  
circumferential portions 1a and 2a are sealed with a movable seal means 4  
which can be elastically deformed in a vertical direction, a closed space (S)  
15 is formed such that the both substrates A and B can be surrounded and the  
both substrates A and B are made to approach up to a certain interval in the  
closed space (S); a step in which the air in the closed space (S) is removed,  
the both pressing plates 1 and 2 are adjusted and moved relatively in the  
 $XY\theta$  directions, and both substrates A and B are roughly aligned; a step in  
20 which after the closed space (S) obtains a certain degree of vacuum, the  
movable seal means 4 is deformed so that the both substrates A and B can  
approach to be closed up to a position where the both substrates A and B  
are closed with an annular adhesive (C); a step in which the both pressing  
plates 1 and 2 are adjusted and moved relatively in the  $XY\theta$  directions and  
25 the move closely approached substrates A and B are precisely aligned; and

a step in which one of the substrates A and B is released from one of the pressing plats 1 and 2, the closed space (S) is returned to have the atmospheric pressure, and the both substrates A and B are uniformly pressed and filled up to a certain gap according to a difference between an inner pressure and an outer pressure of the substrates A and B, and the above steps are sequentially performed.

**[Claim 3]**

The apparatus of claim 1, wherein the second pressing means 7 includes a flexible thin plate member 7b which closes a recess portion 1b formed at a central portion of the facing surface of one pressing plate 1, supports the substrate 'A' such that it cannot be moved, and is elastically deformed only in the vertical direction, and a pressing unit 7c which evacuates air from the recess portion 1b closed by the flexible thin plate member 7b and deforms the flexible thin plate member 7b so that it can bounce up toward the other substrate 'B' when the substrates are precisely aligned.

**[Claim 4]**

The method of claim 2, further comprising a step in which one substrate A is supported so as not to be moved on a flexible thin plate member 7b which closes a recess portion 1b formed at a central portion of the facing surface of one pressing plate 1 and is elastically deformed only in the vertical direction; a step in which the substrates are roughly aligned by making an internal pressure of the closed recess portion 1b and that of the

closed space (S) same; and a step in which after the rough aligning, when the closed space (S) obtains a certain degree of vacuum, the flexible thin plate member 7b is deformed to bounce up according to an increase in the internal pressure of the closed recess portion 1b, and the substrate A supported thereon is made to approach more closely to the other substrate B.

**[Claim 5]**

The method of claim 2 or 4, wherein a suitable amount of liquid crystals is injected between the both substrates A and B before the substrates are roughly aligned.

**[Title of the Invention]**

**APPARATUS AND METHOD FOR LAMINATING SUBSTRATES FOR LIQUID  
CRYSTAL PANEL**

5 **[Detailed description of the Invention]**

**[Field of the Invention]**

The present invention relates to an apparatus and method for laminating substrates for a liquid crystal panel for aligning (rough aligning and fine aligning) two sheets of substrates in a vacuum state in a process of  
10 fabricating the liquid crystal panel used for a liquid crystal display (LCD), and more particularly, to an apparatus and method for laminating substrates for a liquid crystal panel in which two sheets of substrates, of which detachment and attachment are freely supported by a pair of pressing plates, are folded in a vacuum state, roughly aligned and precisely aligned by  
15 adjusting and moving them relatively in  $XY\theta$  directions by a position determining unit, and then pressed to fill to have a certain gap.

**[Description of the Prior Art]**

In a related art apparatus and method for laminating substrates for a  
20 liquid crystal panel as shown in Figure 5, a vacuum chamber 11, which surrounds a pair of upper and lower pressing plates 1' and 2' and a position determining unit 8' such as an XY table, is formed to be opened/closed freely. A driving shaft 8c' connecting the position determining unit 8' and a driving source 8b' penetrates the vacuum chamber 11 by means of a vacuum  
25 penetrating part 12 such as bellows. After the interior of the vacuum

chamber 11 is closed to be form a vacuum therein, the position determining unit 8' is operated through the driving shaft 8c'to thereby adjust and move the both pressing plates 1' and 2' in the XYθ directions to roughly and precisely aligning the both substrates A and B.

5

**[Problems to be solved by the Invention]**

However, in the related art apparatus and method for laminating the substrates for the liquid crystal panel, since the substrates are aligned in the XYθ directions in the vacuum chamber by driving the position determining unit from outside, vacuum penetrating components of the driving shaft are complicated, forming a vacuum inside and outside the vacuum chamber incurs a high cost. In addition, a considerable force is required for roughly aligning and precisely aligning according to viscosity of a sealant and there are many restrictions in a driving form. Moreover, because the vacuum chamber encompass the pair of upper and lower pressing plates and the position determining unit, the internal space where a vacuum to be formed increases, which needs to increase capacity of a vacuum pump and limits the size of used substrates, so a large-scale substrate cannot be fabricated.

An object of the present invention as recited in claims 1 and 2 is to hermetically close the portion only between both pressing plates and move it in XYθ directions from outside and aligned. An object of the present invention as recited in claims 3 and 4 in addition to the object as recited in claim 1 or 2 is to prevent partial pressing onto each substrate regardless of flatness or parallel precision of a rigid pressing plate. An object of the present invention as recited in claim 5 in addition to the object as recited in



claim2 or 4 is to fabricate a liquid crystal panel without injecting liquid crystals in a follow-up process.

[Means for solving the problem]

5           To achieve these and other advantages and in accordance with the purpose of the present invention, as embodied and broadly described herein, there is provided an apparatus for laminating substrates for a liquid crystal panel as recited in claim 1 including: a support means 3 for supporting the substrates A and B installed on the facing surfaces of the both pressing  
10   plats 1 and 2 such that they cannot be moved; a movable seal means 4 for supporting freely movement relatively in the  $XY\theta$  directions in a state that the circumferential portions 1a and 2a facing the both pressing plates 1 and 2 are hermetically closed, and elastically deformed in a vertical direction; a first pressing means 5 for moving the both pressing plates 1 and 2 to  
15   approach relatively with each other, forming a closed space (S) such that the both substrates A and B can be surrounded between the both pressing plates 1 and 2, and approaching the both substrates A and B each other up to a certain interval; a suction means 6 for removing air in the closed space (S) to form a vacuum therein; a second pressing means 7 for approaching  
20   the both substrates A and B which has been approached by the first pressing means 5 to be closer up to a position where the substrates A and B can be hermetically closed with an annular adhesive (C); and a position determining unit 8 for adjusting and moving the both pressing plates 1 and 2 relatively in the  $XY\theta$  directions in a state that the first and second pressing  
25   means 5 and 7 are operating, and installed outside the closed space (S).

A method for laminating substrates for a liquid crystal panel as recited in claim 2, includes: a step in which the two sheets of substrates A and B are supported on facing surfaces of the both pressing plates 1 and 2 such that they cannot be moved; a step in which as the both pressing plates 1 and 2 approach, the facing circumferential portions 1a and 2a are sealed with a movable seal means 4 which can be elastically deformed in a vertical direction, a closed space (S) is formed such that the both substrates A and B can be surrounded and the both substrates A and B are made to approach up to a certain interval in the closed space (S); a step in which the air in the closed space (S) is removed, the both pressing plates 1 and 2 are adjusted and moved relatively in the XYθ directions, and both substrates A and B are roughly aligned; a step in which after the closed space (S) obtains a certain degree of vacuum, the movable seal means 4 is deformed so that the both substrates A and B can approach to be closed up to a position where the both substrates A and B are closed with an annular adhesive (C); a step in which the both pressing plates 1 and 2 are adjusted and moved relatively in the XYθ directions and the move closely approached substrates A and B are precisely aligned; and a step in which one of the substrates A and b is released from one of the pressing plats 1 and 2, the closed space (S) is returned to have the atmospheric pressure, and the both substrates A and B are uniformly pressed and filled up to a certain gap according to a difference between an inner pressure and an outer pressure of the substrates A and B, and the above steps are sequentially performed.

The second pressing means 7 of the apparatus of claim 1 as recited in claim 3 includes a flexible thin plate member 7b which closes a recess

portion 1b formed at a central portion of the facing surface of one pressing plate 1, supports the substrate 'A' such that it cannot be moved, and is elastically deformed only in the vertical direction, and a pressing unit 7c which sucks air from the recess portion 1b closed by the flexible thin plate member 7b and deforms the flexible thin plate member 7b so that it can bounce up toward the other substrate 'B' when the substrates are precisely aligned.

The method as recited in claim 4 comprises further to claim 2; a step in which one substrate A is supported so as not to be moved on a flexible thin plate member 7b which closes a recess portion 1b formed at a central portion of the facing surface of one pressing plate 1 and is elastically deformed only in the vertical direction; a step in which the substrates are roughly aligned by making an internal pressure of the closed recess portion 1b and that of the closed space (S) same; and a step in which after the rough aligning, when the closed space (S) obtains a certain degree of vacuum, the flexible thin plate member 7b is deformed to bounce up according to an increase in the internal pressure of the closed recess portion 1b, and the substrate A supported thereon is made to approach more closely the other substrate B.

In the method as recited in claim 5 in addition to claim 2 or 4, a suitable amount of liquid crystals is injected between the both substrates A and B before the substrates are roughly aligned.

#### [Operation]

The present invention recited in claims 1 and 2 features that pressing

plates supporting two sheets of substrates move to approach to close by means of a movable seal unit mutual circumferential portions to thereby form a closed space, both substrates approach until they have a certain gap therebetween, air in the closed space is removed, the both pressing plates  
5 are adjusted and moved relatively in  $XY\theta$  directions, and both substrates are roughly aligned, and then, when a certain vacuum degree is obtained, the movable seal unit is deformed to make both substrates approach until they are closed with an annular adhesive, and in this state, the both pressing plates are adjusted and moved relatively in the  $XY\theta$  directions, both  
10 substrates are precisely aligned and then released from only one side of the pressing plates, and then, the closed space is returned to an atmospheric pressure so that the both substrates can be uniformly pressed according to a pressure difference made between the inside and the outside to thereby form a certain gap.

15 The present invention as recited in claims 3 and 4 features with respect to the construction as recited in claim 1 that a second pressing means includes a flexible thin plate member for closing a recess portion formed at the central portion of a facing surface of one pressing plate and elastically deformed only in a vertical direction so as to support to prevent  
20 movement of one substrate; and a pressing unit for sucking a gas in the recess portion closed by the flexible thin plate member to deform the flexible thin plate member to bounce up toward the other substrate during fine aligning, or features with respect to the constructed as recited in claim 2 that a step of supporting to prevent movement of one substrate on the  
25 flexible thin plate member closing the recess portion formed at the central

portion of the facing surface of one pressing plate and elastically deformable only in the vertical direction; a step of performing aligning roughly by making an internal pressure of the closed recess portion and an internal pressure of the closed space same; a step of deforming the flexible thin plate member so as to bounce up according to increase in the internal pressure of the closed recess portion after the interior of the closed space reaches a vacuum degree following the roughly aligning, and moving the substrate supported thereon so as to be closed to the other substrate. By doing that, after the roughly aligning, the flexible thin plate member is deformed to bounce up according to the increase in the internal pressure of the closed recess portion, the substrate supported thereon is moved to more approach the other substrate, and then, the gap between the both substrates is closed by the annular adhesive 'C', whereby the both substrates can be uniformly filled near a final gap during precisely aligning.

The present invention as recited in claim 5 features with respect to the construction as recited in claim 2 or 4 that a suitable amount of liquid crystals are injected between both substrates before performing the roughly aligning. Thus, the atmosphere in the closed space is returned to the atmospheric pressure and the both substrates are uniformly pressed to be filled according to the difference between pressures formed the outside and the inside of the both substrates, and in the state that the liquid crystals are sealed, a certain gap can be formed.

**[Embodiment of the invention]**

The present invention will now be described with reference to the

accompanying drawings. As shown in Figures 1 and 2, an upper pressing plate 1 is an upper base plate which is supported to be reciprocally moved in a vertical direction freely but cannot be moved in  $XY\theta$  directions, and a lower pressing plate 2 is a lower base plate which is supported to be freely adjusted and moved in the  $XY\theta$  directions through a position determining unit 8 such as, for example, an XY table on a fixing plate 9. Two sheets of glass substrates A and B adsorbed and supported on facing surfaces of the upper and lower base plates 1 and 2 are aligned at a vacuum atmosphere.

The upper and lower base plates 1 and 2 are formed of a rigid body such as a metal or carbon. A plurality of suction holes as a support unit 3 are formed at the central portion of the facing surfaces to prevent movement of the both substrates A and B. The suction holes 3 and an absorption source (not shown) such as a vacuum pump are connected through a pipe. An operation of the absorption source is controlled by a controller (not shown). Absorption operation is initiated at an initial stage that the both substrates A and B are set. After the both substrates A and B are precisely aligned, one of the substrates, namely, the upper substrate 'A' in this embodiment, is released from being adsorbed, and then, after the closed space 'S' (to be described) is returned to the atmospheric pressure, the lower substrate 'B' is released from being adsorbed and returned to its initial state.

The substrates A and B are formed as a color filter and TFT substrates with a desired pattern formed thereon. An annular adhesive 'C' is coated on the edge portion along a circumferential portion of one of the facing surfaces of the substrates, namely, of the lower substrate 'B' in this

embodiment, and a plurality of spacers (not shown) can spread on the other substrate as necessary.

A movable seal unit 4, which is positioned between a circumferential portion 1a of the upper base plate 1 and a circumferential portion 2a of the lower base plate 2 to support the both base plates so as to be movable in the XY $\theta$  directions in a state that the both base plates 1 and 2 are maintained in a closed state, is installed in an annular form to surround the both substrates A and B. In this embodiment, the movable seal unit 4 includes a movable block 4a having a circular or spherical shape in its section according to a plane form of the upper and lower base plates 1 and 2, an annular seal material 4b which contact with or released from the circumferential portion 1a of the upper base plate 1 mounted on an upper surface of the movable block 4a, and elastically deformed in a vertical direction of such as an O ring, a driving vacuum seal 4c which usually contacts with the circumferential portion 2a of the lower base plate 2 mounted on a lower surface of the movable block 4a and uses, for example, a vacuum grease as necessary, and a load support ball 4d supporting such that force such as weight of the upper base plate 1 or the movable block 4a does not work on the driving vacuum seal 4c.

In particular, as necessary, a plurality of connection pins 4e are penetratingly inserted over the upper base plate 1 and the movable block 4a in order to integrally connect them such that they can be moved in the vertical direction but not in the XY $\theta$  directions. Preferably, an elastic member 4f such as a tensile spring is installed at the movable block 4 and the lower base plate 2 in order to prevent separation of them in the vertical direction.

A first pressing unit formed of, for example, a vertically driving cylinder is connected with the upper base plate 1. An operation of the first pressing unit 5 is controlled by a controller (not shown). In an initial state where the substrates A and B are set, the upper base plate 1 is in a standby state as indicated by a dotted line as shown in Figures 1 and 2a. When the substrates A and B are completely set, the base plate 1 is lowered, a space 'S' closed between the upper and lower substrates 1 and 2 surrounds the both substrates A and B as indicated by a straight line in Figure 1 and Figure 2b. After the both substrates A and b are precisely aligned, of after the closed space 'C' is returned to the atmospheric pressure, the base plate 1 is lifted to be returned to its initial state.

As indicated by a reference numeral 6 in Figure 1, a suction unit is installed in the closed space 'S', which is connected with a vacuum pump installed outside and sucking air in the closed space 'S' to obtain a certain vacuum degree therein. An operation of the suction unit 7 is controlled by the controller (not shown). The suction unit initiates sucking in the closed space 'S' when the closed space 'S' is formed as the upper and lower base plates 1 and 2 approach. And then, after the both substrates A and B are precisely aligned, the suction unit supplies air to the closed space 'S' to return it to the atmospheric pressure.

A second pressing unit 7 is installed to make the both substrates A and B which have approached by the first pressing unit 5 more approach up to a position where they are closed with the annular adhesive 'C'. In this embodiment, the second pressing unit 7 is formed as a cylinder 7a which can be expanded and contracted in a vertical direction from an upper



surface of the movable block 4a to the circumferential portion 1a of the upper base plate 1. By contracting the cylinder 7a in the vertical direction, the annular seal 4b can be compressed to be deformed in the vertical direction, whereby the both substrates A and B can be more pressed. An operation of the second pressing unit 7 is controlled by the controller (not shown). At an initial state, the second pressing unit is expanded in the vertical direction as shown in Figure 2a. After the both substrates A and B are roughly aligned, the second pressing unit 7 is contracted as shown in Figure 2c. And then, after the both substrates A and B are precisely aligned or after the closed space 'S' (to be described) is returned to the atmospheric pressure, the second pressing unit 7 is lifted to be returned to its initial state.

The position determining unit 8 including the XY table 8a and the driving source 8b for moving the lower base plate 2 in the XYθ directions are connected with a lower surface of the lower base plate 2, namely, the outer side of the closed space 'S'. By driving the driving source 8b based on data of marks indicated at both substrates A and B and outputted from a detecting unit 8c including a microscope and a camera, the lower base plate 2 and the lower substrate 'B' supported thereon can be adjusted and moved in the XYθ directions, and the roughly aligning and precisely aligning are performed.

A buffer 10 can be formed as necessary at a central portion which contacts with the both substrates A and B of the facing surfaces of the upper and lower base plates 1 and 2. The buffer 10 is made of a material with excellent cushion characteristics and has such a thickness as not to generate misalignment when the both substrates A and B are adjusted and

moved in the  $XY\theta$  directions by the position determining unit 8. In this embodiment, the buffer 10 with a thickness of a few millimeters is formed only on the facing surface 2b of the lower base plate 2, but the present invention is not limited thereto, and the buffer can be installed at both facing surfaces of the upper and lower base plates 1 and 2 or only at the facing surface of the upper base plate 1.

The method for laminating the substrates for a liquid crystal panel will now be described according to a process order.

First, as shown in Figure 2a, the substrates A and B are set to be pre-aligned on the facing surfaces of the upper and lower base plates 1 and 2. And then, the both substrates A and B are adsorbed and supported by the support unit 3 so that they cannot be moved.

Thereafter, as shown in Figure 2b, the upper and lower base plates 1 and 2 approach by operating the first pressing unit 5, and the circumferential portion 1a of the upper base plate 1 is tightly attached with the annular seal 4b. Then, the closed space 'S' is formed to encompass the both substrates A and B sealed between the upper and lower base plates 1 and 2.

At the same time, the both substrates A and B approach up to a certain interval therebetween and face with a gap of 1mm or below. However, the substrate 'A' does not contact with the annular adhesive 'C' and the closed space 'S' communicates between the both substrates A and B.

Thereafter, as air is removed from the closed space 'S' by operating the suction unit 6, the space 'S' has a vacuum formed therein, and also air is removed from the interval between the both substrates A and B to form a

vacuum therein. IN this state, the upper and lower base plates 1 and 2 are adjusted and moved relatively in the  $XY\theta$  directions by the position determining unit 8, and the both substrates A and B are roughly aligned.

When a certain degree of vacuum is obtained, as shown in Figure 2c,  
5 the upper and lower base plates 1 and 2 approach further by operating the second pressing unit 7 to compress and deforms the annular seal 4b, according to which the both substrates A and B approach to be more closed. And then, as the substrate 'A' is tightly attached on the annular adhesive 'C' coated on the substrate 'B', the both substrates A and B are hermetically  
10 closed. IN this state, the upper and lower base plates 1 and 2 are adjusted and moved in the  $XY\theta$  directions by operating the position determining unit 8, and the both substrates A and B are precisely aligned.

Subsequently, as shown in Figure 2d, the upper substrate 'A' is released from the upper base plate 1 by operating the support unit 3, and air  
15 is applied into the closed space 'S' by operating the suction unit 6 to return it to the atmospheric pressure. By doing that, the both substrates A and B are uniformly pressed and filled according to the difference of pressure made between the inside and outside thereof and a certain gap is formed therebetween.

20 In this case, before performing the roughly aligning, specifically when the both substrates A and B are set, a suitable amount of liquid crystals can be sealed in a suitable state. Then, the closed space 'S' can be returned to the atmospheric pressure, so that the both substrates A and B can be uniformly pressed and filled according to the difference of pressure  
25 formed inside and outside the substrates A and B. With the liquid crystals

sealed, a certain gap can be formed, and a liquid crystal panel can be fabricated without injecting liquid crystals in a follow-up process.

Thereafter, when the closed space 'S' is returned to have the atmospheric pressure, the upper and lower base plates 1 and 2 are released by operating the first pressing unit 5, the closed space 'S' is opened, the aligned substrates A and B are taken out, and then, the above-described operations are repeatedly performed.

Accordingly, in the state that only the upper and lower base plates 1 and 2 are hermetically closed, they can be moved in the XYθ directions and aligned from outside. As a result, the position determining unit 8 or the driving source 8b can be installed in the air, general components can be used and a vacuum penetrating component is not necessary, making the structure simple. In addition, since no cost incurs for forming a vacuum and not much force is required for the roughly aligning and precisely aligning, there is no limitation in a driving form. Moreover, the vacuum space can be minimized, which reduces capacity of the vacuum pump as much, and productivity of a large-scale substrate can be enhanced.

When the buffer 10 with the excellent cushion characteristics is installed as necessary on one or both facing surfaces of the upper and lower base plates 1 and 2 such that misalignment does not occur in the adjusting and moving in the XYθ directions, a phenomenon that only one side of the upper and lower base plates 1 and 2 contacts is prevented and thus a uniform gap can be easily formed.

Figures 3 and 4d shows a different embodiment of the present invention. This embodiment is different from the former embodiment in that,

in place of the cylinder 7a which is installed from the upper surface of the movable block 4a to the circumferential portion 1a of the upper base plate 1 and expands and contracts in the vertical direction, the second pressing unit 7 includes a flexible thin plate member 7b which closes a recess portion 1b  
5 formed at the central portion of the facing surface of the upper base plate 1, supports the upper substrate 'A' such that it cannot be moved, and is elastically deformed only in the vertical direction, and a pressing unit 7c which sucks air in the recess portion 1b closed by the flexible thin plate member 7b and deforms the flexible thin plate member 7b so that it can  
10 bounce up toward the lower substrate 'B' when the substrates are precisely aligned. The other construction is the same as the former embodiment as shown in Figures 1 and 2.

The flexible thin plate member 7b is made of a metal film such as stainless steel so that it can be elastically deformed in the vertical direction  
15 but not in the XYθ directions, and includes a plurality of suction holes as a support unit 3 formed at the central portion thereof. The pressing unit 7c, which is controlled by a controller (not shown), sucks air so that an internal pressure of the closed recess portion 1b is the same as that of the closed space 'S' by means of the suction unit 6 in the above state as shown in  
20 Figure 4a and until the roughly aligning is performed. After the roughly aligning is performed, as shown in Figure 4c, the pressing unit 7c applies air so that the internal pressure of the closed recess portion 1b can be higher than that of the closed space 'S'.

After the roughly aligning is performed, as shown in Figure 4c, the  
25 flexible thin plate member 7b is deformed to bounce up according to

increase in the internal pressure of the closed recess portion 1b, and the upper substrate 'A' supported thereon is made to approach closer the lower substrate 'B', which is then closed with the annular adhesive 'C', whereby the both substrates A and B can be uniformly filled up to near a final gap when they are precisely aligned.

As a result, compared with the former embodiment as shown in Figures 1 and 2, the rigid upper and lower base plates 1 and 2 can easily cause the partial pressing of the substrates A and B easily according to the flatness of the facing surfaces or parallel precision between the base plates, but the partial pressing of the substrates A and B can be completely prevented and a product cannot be damaged.

In this embodiment, the upper pressing plate 1 is the upper base plate which can be reciprocally moved in the vertical direction freely and the lower pressing plate 2 is the lower base plate which is supported to be freely adjusted and moved in the  $XY\theta$  directions. But the present invention is not limited thereto, and the upper base plate can be supported to be adjusted and moved freely in the  $XY\theta$  directions and the lower base plate can be supported to be movable reciprocally in the vertical direction freely. The aligning is performed under the vacuum atmosphere, but the present invention is not limited thereto and aligning can be performed under a special gas atmosphere.

The substrates A and B, the support unit 3, the movable seal unit 4, the first pressing unit 5, the suction unit 6, the second pressing unit 7 and the position determining unit 8 are not limited to the illustrated structure and can have any structure so long as they can operate in the same manner.

Especially, the support unit 3 for supporting the substrates A and B such that they cannot be moved can use vacuum and absorption by using a vacuum difference by means of the suction unit 6 if a vacuum degree in the closed space 'S', and in this case, if the closed space 'S' has such a high vacuum degree that the vacuum difference cannot be used, an electrostatic chuck or an adhesive film can be used as the support unit 3 so that the substrates A and B cannot be moved. Instead of the driving vacuum seal 4c of the movable seal unit 4, a magnetic fluid type vacuum seal can be used.

10 [Effect of the invention]

As so far described, according to the present invention as recited in claims 1 and 2, the pressing plates supporting two sheets of substrates thereon are moved to approach each other, the mutual circumferential portions are closed by means of a movable seal unit to form a closed space, the both substrates approach up to a certain interval therebetween, the both pressing plates are adjusted and moved in the XYθ directions while moving air existing in the closed space, both substrates are roughly aligned, the movable seal unit is deformed to make both substrates approach up to a position where they can be closed with the annular adhesive when a certain vacuum degree is obtained, the both pressing plates are adjusted and moved in the XYθ directions, both substrates are precisely aligned, the substrate is released only from one pressing plate, and then, the closed space is returned to have the atmospheric pressure, so that the both substrates can be uniformly pressed and filled according to the difference between the inner pressure and outer pressure of both substrates and a gap

is formed. Thus, in the state that only the portion between both pressing plates are hermetically closed, they can be moved in the  $XY\theta$  directions to be aligned from outside.

Accordingly, compared with the related art in which the position determining unit is moved in the  $XY\theta$  directions for aligning in the vacuum chamber upon receiving a driving force from outside, the position determining unit or its driving source can be installed in the air, general components can be used, and a vacuum penetrating component does not need to be used, making the structure simple. In addition, since no cost incurs for forming a vacuum and not much force is required for the roughly aligning and precisely aligning, there is no limitation in a driving form. Moreover, the vacuum space can be minimized, which reduces capacity of the vacuum pump as much, and productivity of a large-scale substrate can be enhanced.

In addition to the effect of the present invention of claims 1 and 2, according to the present invention as recited in claims 3 and 4, after the roughly aligning, the flexible thin plate member is deformed to bounce up according to increase in the internal pressure of the closed recess portion, and the substrate supported thereon is made to approach closer the other lower substrate, which is then closed with the annular adhesive 'C', whereby the both substrates can be uniformly filled up to near the final gap when they are precisely aligned. Accordingly, partial pressing of each substrate can be prevented regardless of the flatness or parallel precision of the pressing plates. Therefore, although the rigid pressing plate can cause the partial pressing of each substrate according to the flatness of the facing



surface or the parallel precision between the base plates, the partial pressing of each substrate can be completely prevented and a product is not damaged.

In addition to the effect of the present invention of claims 2 or 4, according to the present invention as recited in claim 5, since the closed space is returned to have the atmospheric pressure, both substrates can be uniformly pressed and filled according to the difference of inner pressure and outer pressure of both substrates, and in the state that liquid crystals are sealed, the certain gap can be formed. Thus, without injecting liquid crystals in a follow-up process, a liquid crystal panel can be fabricated.

**[Description of drawings]**

Figure 1 is a front vertical sectional view of an apparatus for laminating substrates for a liquid crystal panel in accordance with a first embodiment of the present invention;

Figures 2a to 2d are sectional views showing a sequential process of a method for fabricating a liquid crystal panel;

Figure 3 is a front vertical sectional view of an apparatus for laminating substrates for a liquid crystal panel in accordance with a second embodiment of the present invention;

Figures 4a to 4d are sectional views showing a sequential process of a method for fabricating a liquid crystal panel; and

Figure 5 is a front vertical sectional view of an apparatus for laminating substrates for a liquid crystal panel in accordance with a conventional art.



(19) 日本国特許庁 (J P)

(12) 公開特許公報 (A)

(11) 特許出願公開番号

特開2002-131762

(P2002-131762A)

(43) 公開日 平成14年5月9日 (2002.5.9)

(51) Int.Cl. <sup>7</sup>	識別記号	F I	テマコード(参考)
G 0 2 F 1/1339	5 0 5	G 0 2 F 1/1339	5 0 5 2 H 0 8 8
	1 0 1	1/13	1 0 1 2 H 0 8 9
G 0 9 F 9/00	3 3 8	G 0 9 F 9/00	3 3 8 5 G 4 3 5

審査請求 有 請求項の数 5 O L (全 8 頁)

(21) 出願番号 特願2000-331179(P2000-331179)

(22) 出願日 平成12年10月30日 (2000.10.30)

(71) 出願人 000190105

信越エンジニアリング株式会社

東京都千代田区神田錦町2丁目9番地

(72) 発明者 石坂 一朗

東京都千代田区神田錦町2丁目9番地 信

越エンジニアリング株式会社内

(72) 発明者 宮下 国弘

東京都千代田区神田錦町2丁目9番地 信

越エンジニアリング株式会社内

(74) 代理人 100090619

弁理士 長南 満輝男 (外2名)

最終頁に続く

(54) 【発明の名称】 液晶パネル用基板の貼り合わせ装置及び貼り合わせ方法

(57) 【要約】

【課題】 両加圧板の間のみを密閉状態にしたままその外部でXYθ移動してアライメントする。

【解決手段】 二枚の基板A、Bを保持した加圧板1、2が接近移動することにより、相互の周縁部1a、2aの間を移動シール手段4で密閉して閉空間Sが区画形成されると共に、両基板A、Bが所定間隔まで接近する。その後、この閉空間S内の空気を抜きながら、両加圧板1、2を相対的にXYθ方向へ調整移動させて、両基板A、Bの粗合わせが行われる。所定の真空度に到達してから、上記移動シール手段4を変形させて両基板A、Bの間が環状接着剤Cで密閉される位置まで更に接近し、この状態で、上記両加圧板1、2を相対的にXYθ方向へ調整移動させて、両基板の微合わせが行われる。その後、上記加圧板1、2の一方からのみ基板を解放して、上記閉空間S内を大気圧に戻すことにより、両基板A、Bの内外に生じる気圧差で均等に押し潰されて所定のギャップが形成される。

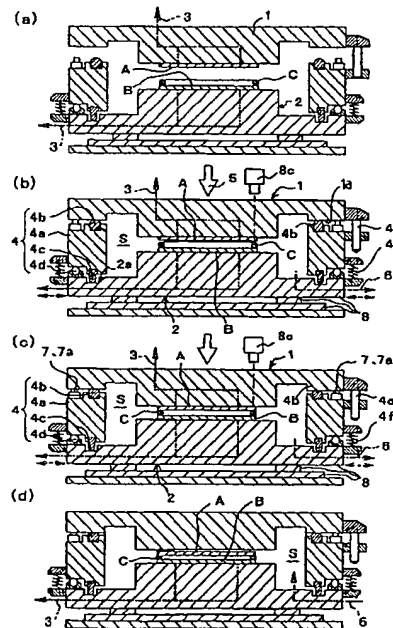

【特許請求の範囲】

【請求項1】 上下一対の加圧板(1, 2)に対して夫々着脱自在に保持された二枚の基板(A, B)を真空中で重ね合わせ、位置決め手段(8)により相対的にXYθ方向へ調整移動して両基板(A, B)の粗合わせ及び微合わせを行い、更に両基板(A, B)を加圧して所定のギャップまで潰す液晶パネル用基板の貼り合わせ装置において、

前記両加圧板(1, 2)の対向面に設けられた基板(A, B)を移動不能に保持する保持手段(3)と、両加圧板(1, 2)の対向する周縁部(1a, 2a)間の密閉状態を維持したまま相対的にXYθ方向へ移動自在に支持する上下方向へ弾性変形可能な移動シール手段(4)と、両加圧板(1, 2)を相対的に接近移動して、これら両加圧板(1, 2)の間に両基板(A, B)が囲まれるように閉空間(S)を区画形成すると共に、両基板(A, B)を所定間隔まで接近させる第一加圧手段(5)と、上記閉空間(S)内の気体を出し入れして所定の真空度にする吸気手段(6)と、

上記第一加圧手段(5)により接近させた両基板(A, B)を、それらの間が環状接着剤(C)で密閉される位置まで更に接近させる第二加圧手段(7)と、上記第一加圧手段(5)及び第二加圧手段(7)の作動状態で、両加圧板(1, 2)を相対的にXYθ方向へ調整移動させるための閉空間(S)外に配設した位置決め手段(8)と、を備えたことを特徴とする液晶パネル用基板の貼り合わせ装置。

【請求項2】 上下一対の加圧板(1, 2)に対して夫々着脱自在に保持された二枚の基板(A, B)を真空中で重ね合わせ、位置決め手段(8)により相対的にXYθ方向へ調整移動して両基板(A, B)の粗合わせ及び微合わせを行い、更に両基板(A, B)を加圧して所定のギャップまで潰す液晶パネル用基板の貼り合わせ方法において、

前記両加圧板(1, 2)の対向面に夫々二枚の基板(A, B)を移動不能に保持するステップと、これら両加圧板(1, 2)の接近移動により、相互の対向する周縁部(1a, 2a)の間を上下方向へ弾性変形可能な移動シール手段(4)で密閉して、両基板(A, B)が囲まれるように閉空間(S)を区画形成すると共に、該閉空間(S)内の両基板(A, B)を所定間隔まで接近させるステップと、この閉空間(S)内の空気を抜きながら、両加圧板(1, 2)を相対的にXYθ方向へ調整移動させて、両基板(A, B)の粗合わせを行うステップと、この閉空間(S)内が所定の真空度に到達してから、上記移動シール手段(4)を変形させて、両基板(A, B)の間が環状接着剤(C)で密閉される位置まで更に接近させるステップと、

上記両加圧板(1, 2)を相対的にXYθ方向へ調整移動させて、更に接近した両基板(A, B)の微合わせを行うステップと、

上記加圧板(1, 2)のどちらか一方から一枚の基板(A, B)を解放させ、上記閉空間(S)内を大気圧に戻して、両基板(A, B)の内外に生じる気圧差により所定のギャップまで均等に押し潰すステップとからなり、

これらのステップを順次行うことを特徴とする液晶パネル用基板の貼り合わせ方法。

【請求項3】 前記第二加圧手段(7)が、一方加圧板(1)の対向面中央に形成された凹部(1b)を閉塞すると共に、一方基板(A)を移動不能に保持する上下方向のみ弾性変形可能な可撓性薄板材(7b)と、

この可撓性薄板材(7b)で閉鎖された凹部(1b)内の気体を出し入れして、微合わせ時に可撓性薄板材(7b)が他方基板(B)へ向け膨出するように変形させる加圧部(7c)と、からなる請求項1記載の液晶パネル用基板の貼り合わせ装置。

【請求項4】 前記一方加圧板(1)の対向面中央に形成された凹部(1b)を閉塞する上下方向のみ弾性変形可能な可撓性薄板材(7b)に、一方基板(A)を移動不能に保持するステップと、

上記閉鎖凹部(1b)の内圧と閉空間(S)の内圧を同じにして粗合わせするステップと、

この粗合わせ後に、閉空間(S)内が所定の真空度に到達してから、上記閉鎖凹部(1b)の内圧上昇により可撓性薄板材(7b)を膨出変形させて、それに保持された一方基板(A)を他方基板(B)へ向け更に接近移動させるステップと、を有する請求項2記載の液晶パネル用基板の貼り合わせ方法。

【請求項5】 前記粗合わせを行う前の時点で、両基板(A, B)の間に適正量の液晶を注入した請求項2または4記載の液晶パネル用基板の貼り合わせ方法。

【発明の詳細な説明】

【0001】

【発明の属する技術分野】本発明は、液晶ディスプレイ(LCD)に使用する液晶パネルの製造過程において、二枚の液晶パネル用基板を真空中でアライメント(粗合わせ及び微合わせ)するための液晶パネル用基板の貼り合わせ装置及び貼り合わせ方法に関する。詳しくは、上下一対の加圧板に対して夫々着脱自在に保持された二枚の基板を真空中で重ね合わせ、位置決め手段により相対的にXYθ方向へ調整移動して両基板の粗合わせ及び微合わせを行い、更に両基板を加圧して所定のギャップまで潰す液晶パネル用基板の貼り合わせ装置及び貼り合わせ方法に関する。

【0002】

【従来の技術】従来、この種の液晶パネル用基板の貼り

合わせ装置及び貼り合わせ方法は、例えば図5に示すように、上下一対の加圧板1'、2'と例えばXYテーブルなどの位置決め手段8'の全体を囲むように真空チャンパー11が上下方向へ開閉自在に形成され、この位置決め手段8'とその駆動源8b'とを連絡する駆動軸8c'が、例えばベローズなどの真空貫通部品12により真空チャンパー11を貫通して設けられている。そして、上記真空チャンパー11が閉じられてその内部を真空にした後、その外部から駆動軸8c'で位置決め手段8'を作用して両加圧板1'、2'が相対的にXYθ方向へ調整移動されることにより、両基板A、Bの粗合わせ及び微合わせを行っていた。

【0003】

【発明が解決しようとする課題】しかし乍ら、このような従来の液晶パネル用基板の貼り合わせ装置及び貼り合わせ方法では、外部から駆動伝達により真空チャンパー内の位置決め手段をXYθ移動してアライメントするため、駆動軸の真空貫通部品が複雑化して、真空チャンパー内外の真空遮断にコストがかさむだけでなく、シール材の粘度によっては、粗合わせや微合わせに相当な力が必要で、駆動形態の制約が多いという問題がある。また、真空チャンパーが上下一対の加圧板及び位置決め手段の全体を囲むため、真空となる空間が大きくなってしまい、真空ポンプの容量を大きくする必要があると共に、使用できる基板の大きさにも限界があって、大型の基板は製造できないという問題がある。

【0004】本発明のうち請求項1、2記載の発明は、両加圧板の間のみを密閉状態にしたままその外部でXYθ移動してアライメントすることを目的としたものである。請求項3、4記載の発明は、請求項1または2に記載の発明の目的に加えて、剛体製加圧板の平坦度や平行精度に関係なく基板同士の局所加圧を防止することを目的としたものである。請求項5記載の発明は、請求項2または4に記載の発明の目的に加えて、ので、後工程で液晶を注入せずに液晶パネルを制作することを目的としたものである。

【0005】

【課題を解決するための手段】前述した目的を達成するために、本発明のうち請求項1記載の発明は、両加圧板の対向面に設けられた基板を移動不能に保持する保持手段と、両加圧板の対向する周縁部間の密閉状態を維持したまま相対的にXYθ方向へ移動自在に支持する上下方向へ弾性変形可能な移動シール手段と、両加圧板を相対的に接近移動して、これら両加圧板の間に両基板が囲まれるように閉空間を区画形成すると共に、両基板を所定間隔まで接近させる第一加圧手段と、上記閉空間内の気体を出し入れして所定の真空度にする吸気手段と、上記第一加圧手段により接近させた両基板を、それらの間が環状接着剤で密閉される位置まで更に接近させる第二加圧手段と、上記第一加圧手段及び第二加圧手段の作動状

態で、両加圧板を相対的にXYθ方向へ調整移動させるための閉空間外に配設した位置決め手段と、を備えたことを特徴とするものである。請求項2記載の発明は、両加圧板の対向面に夫々二枚の基板を移動不能に保持するステップと、これら両加圧板の接近移動により、相互の対向する周縁部の間を上下方向へ弾性変形可能な移動シール手段で密閉して、両基板が囲まれるように閉空間を区画形成すると共に、該閉空間内の両基板を所定間隔まで接近させるステップと、この閉空間内の空気を抜きながら、両加圧板を相対的にXYθ方向へ調整移動させて、両基板の粗合わせを行うステップと、この閉空間内が所定の真空度に到達してから、上記移動シール手段を変形させて、両基板の間が環状接着剤で密閉される位置まで更に接近させるステップと、上記両加圧板を相対的にXYθ方向へ調整移動させて、更に接近した両基板の微合わせを行うステップと、上記加圧板のどちらか一方から一枚の基板を解放させ、上記閉空間内を大気圧に戻して、両基板の内外に生じる気圧差により所定のギャップまで均等に押し潰すステップとからなり、これらのステップを順次行うことを特徴とするものである。請求項3記載の発明は、請求項1記載の発明の構成に、前記第二加圧手段が、一方加圧板の対向面中央に形成された凹部を閉塞すると共に一方基板を移動不能に保持する上下方向のみ弾性変形可能な可撓性薄板材と、この可撓性薄板材で閉鎖された凹部内の気体を出し入れして微合わせ時に可撓性薄板材が他方基板へ向け膨出するように変形させる加圧部とからなる構成を加えたことを特徴とする。請求項4記載の発明は、請求項2記載の発明の構成に、前記一方加圧板の対向面中央に形成された凹部を閉塞する上下方向のみ弾性変形可能な可撓性薄板材に一方基板を移動不能に保持するステップと、上記閉鎖凹部の内圧と閉空間の内圧を同じにして粗合わせするステップと、この粗合わせ後に閉空間内が所定の真空度に到達してから上記閉鎖凹部の内圧上昇により可撓性薄板材を膨出変形させてそれに保持された一方基板を他方基板へ向け更に接近移動させるステップとを有する構成を加えたことを特徴とする。請求項5記載の発明は、請求項2または4記載の発明の構成に、前記粗合わせを行う前の時点で、両基板の間に適正量の液晶を注入した構成を加えたことを特徴とする。

【0006】

【作用】請求項1、2の発明は、二枚の基板を保持した加圧板が接近移動することにより、相互の周縁部の間を移動シール手段で密閉して閉空間が区画形成されると共に、両基板が所定間隔まで接近し、その後、この閉空間内の空気を抜きながら、両加圧板を相対的にXYθ方向へ調整移動させて、両基板の粗合わせが行われ、所定の真空度に到達してから、上記移動シール手段を変形させて両基板の間が環状接着剤で密閉される位置まで更に接近し、この状態で、上記両加圧板を相対的にXYθ方向

へ調整移動させて、両基板の微合わせが行われ、その後、上記加圧板の一方からのみ基板を解放して、上記閉空間内を大気圧に戻すことにより、両基板の内外に生じる気圧差で均等に押し潰されて所定のギャップが形成されるものである。請求項3、4の発明は、請求項1記載の構成に対して、前記第二加圧手段が、一方加圧板の対向面中央に形成された凹部を閉塞すると共に一方基板を移動不能に保持する上下方向のみ弾性変形可能な可撓性薄板材と、この可撓性薄板材で閉鎖された凹部内の気体を出し入れして微合わせ時に可撓性薄板材が他方基板へ向け膨出するように変形させる加圧部とからなる構成を追加するか、または或いは請求項2記載の構成に対して、前記一方加圧板の対向面中央に形成された凹部を閉塞する上下方向のみ弾性変形可能な可撓性薄板材に一方基板を移動不能に保持するステップと、上記閉鎖凹部の内圧と閉空間の内圧を同じにして粗合わせするステップと、この粗合わせ後に閉空間内が所定の真空度に到達してから上記閉鎖凹部の内圧上昇により可撓性薄板材を膨出変形させてそれに保持された一方基板を他方基板へ向け更に接近移動させるステップとを有する構成を追加したので、粗合わせ後、閉鎖凹部の内圧上昇により可撓性薄板材が膨出変形して、それに保持された一方基板を他方基板へ更に接近して両者が環状接着剤Cで密閉させることにより、これら両基板が微合わせ時に最終ギャップ近くまで均等に潰される。請求項5の発明は、請求項2記載または請求項4記載の構成に対して、前記粗合わせを行う前の時点で、両基板の間に適量の液晶を注入した構成を追加したので、閉空間内の雰囲気は大気圧に戻すことにより、両基板の内外に生じる気圧差で均等に押し潰されて、液晶が封入された状態で所定のギャップ形成が可能となる。

【0007】

【発明の実施の形態】以下、本発明の実施例を図面に基づいて説明する。この実施例は、図1～図2に示す如く上方の加圧板1が、上下方向へは往復動自在だがXYθ方向へは移動不能に支持された上定盤であると共に、下方の加圧板2が固定台板9上に例えばXYテーブルなどの位置決め手段8を介してXYθ方向へ調整移動自在に支持された下定盤であり、これら上定盤1及び下定盤2の対向面に吸着保持した二枚のガラス製基板A、Bを、真空雰囲気中でアライメントするものである。

【0008】上定盤1及び下定盤2は、例えば金属やカーボンなどの剛体で構成され、これら対向面の中央部には、両基板A、Bを移動不能に保持する保持手段3として複数の吸引孔が開孔され、これら吸引孔3…と例えば真空ポンプなどの吸引源（図示せず）とを配管連絡させる。この吸引源は、コントローラー（図示せず）で動作制御され、両基板A、Bをセットする初期状態に吸引が開始され、両基板A、Bの微合わせ後にどちらか一方、本実施例では上方基板Aの吸引を解除し、後述する閉空

間Sが大気圧に戻った後は下方基板Bの吸引を解除して初期状態に戻す。

【0009】これら基板A、Bには、例えば所望のパターンが形成されたカラーフィルターとTFT基板からなり、これら対向面のどちらか一方、図示例の場合には下方の基板Bの周縁部に沿って環状接着剤Cが棒状に塗布され、必要に応じて他方には多数のスペーサ（図示せず）が散布される。

【0010】更に、上定盤1の周縁部1aと下定盤2の周縁部2aとの間には、これら両者間の密閉状態を維持したまま相対的にXYθ方向へ移動自在に支持する移動シール手段4が、両基板A、Bを囲むように環状に設けられる。この移動シール手段4は、本実施例の場合、上定盤1及び下定盤2の平面形状に合わせて断面円形又は矩形に形成された移動ブロック4aと、この移動ブロック4aの上面に装着した上定盤1の周縁部1aと接離する例えばOリングなどの上下方向へ弾性変形可能な環状シール材4bと、移動ブロック4aの下面に装着した下定盤2の周縁部2aと常時接触する必要に応じて例えば真空グリースが使用された駆動真空シール4cと、この駆動真空シール4cに上定盤1や移動ブロック4aの重量などの力が作用しないように支持する荷重受ボール4dとから構成される。

【0011】特に必要に応じて、これら上定盤1と移動ブロック4aがXYθ方向へ一体的に連結させるために、上定盤1から移動ブロック4aに亘って複数本の連結ピン4eを、上下方向へは往復動自在であるがXYθ方向へは移動不能に挿通させることが好ましく、更に移動ブロック4aと下定盤2が上下方向へ離れるのを防止するために両者に亘って例えば引っ張りバネなどの弾性材料4fを掛け渡すことが好ましい。

【0012】そして、上定盤1には、図1の符号5に示すような例えば上下駆動用シリンダーなどからなる第一加圧手段が連設される。この第一加圧手段5は、コントローラー（図示せず）で動作制御され、基板A、Bをセットする初期状態で、図1の一点鎖線及び図2(a)に示す如く上定盤1を上限位置で待機しており、基板A、Bのセット完了後に、図1の実線及び図2(b)に示す如く上定盤1を下降させて、下定盤2との間に閉空間Sが両基板A、Bを囲むように区画形成し、両基板A、Bの微合わせ終了後か、或いは後述する閉空間Sが大気圧に戻った後は上昇させて初期状態に戻す。

【0013】この閉空間Sには、図1の符号6に示すような外部に配設した例えば真空ポンプと連絡して、該閉空間S内の気体、本実施例では空気を出し入れして所定の真空度にする吸気手段が設けられる。この吸気手段6は、コントローラー（図示せず）で動作制御され、上定盤1及び下定盤2の接近移動により閉空間Sが形成された後に閉空間Sから吸気を開始し、両基板A、Bの微合わせの終了後は閉空間Sに空気を供給して大気圧に戻

す。

【0014】また、前記第一加圧手段5により接近させた両基板A、Bを、それらの間が環状接着剤Cで密閉される位置まで更に接近させる第二加圧手段7が設けられる。この第二加圧手段7は、本実施例の場合、前記移動ブロック4aの上面から上定盤1の周縁部1aへ向けて配設した上下方向へ伸縮自在なシリンダー7aからなり、このシリンダー7aを上下方向へ短縮化して前記環状シール4bを上下方向へ圧縮変形させることにより、両基板A、Bが更に加圧されるようにしている。更に、この第二加圧手段7は、コントローラー（図示せず）で動作制御され、初期状態で図2(a)に示す如く上下方向へ伸長しており、両基板A、Bの粗合わせ終了後に図2(c)に示す如く短縮させ、両基板A、Bの微合わせ終了後か、或いは後述する閉空間Sが大気圧に戻った後は上昇させて初期状態に戻す。

【0015】そして、前記閉空間Sの外側となる下定盤2の底面には、例えばXYテーブル8aと、下定盤2をXYθ方向へ移動させるための駆動源8bなどからなる位置決め手段8が連設され、両基板A、Bに表示されたマークを顕微鏡とカメラで構成した検出手段8cから出力されるデータに基づいて駆動源8bを動作させることにより、下定盤2及びこれに保持された下方基板BがXYθ方向へ調整移動して、粗合わせと微合わせを行う。

【0016】更にまた、必要に応じて、前記上定盤1及び下定盤2の対向面の両基板A、Bと当接する中央部分には、クッション性に優れた材質でありながら上記位置決め手段8によるXYθ方向への調整移動の際に位置ズレが発生しない程度の厚さ寸法に形成された緩衝材10を配設しても良い。図示例の場合には、下定盤2の対向面2bのみに、数mm厚さ寸法の緩衝材10を設けたが、これに限定されず、上定盤1及び下定盤2の対向面の両方か又は上定盤1の対向面のみに緩衝材10に設けても良い。

【0017】次に、斯かる液晶パネル用基板の貼り合わせ方法を工程順に従って説明する。まず、図2(a)に示す如く上定盤1及び下定盤2の対向面に基板A、Bを夫々アライメントしてセットする。それにより、保持手段3で両基板A、Bが夫々移動不能に吸着保持される。

【0018】その後、第一加圧手段5の作動で図2(b)に示す如く上定盤1と下定盤2を互いに近づけ、上定盤1の周縁部1aが環状シール4bに密接して、上定盤1と下定盤2との間には、これら捧持された両基板A、Bを囲むように閉空間Sが区画形成される。

【0019】これと同時に両基板A、Bは、上定盤1と下定盤2の接近移動により、所定間隔まで接近し、この状態で1mm以下の隙間をもって対峙している。しかし、一方の基板Bに塗布した環状接着剤Cには、他方の基板Aが接触せず、これら両基板A、Bの間と閉空間Sは連

通している。

【0020】その後、吸気手段6の作動で閉空間Sから空気が抜かれて所定の真空度になると共に、両基板A、Bの間からも空気が抜かれて真空となる。この状態で、位置決め手段8の作動により上定盤1と下定盤2を相対的にXYθ方向へ調整移動させて、両基板A、Bの粗合わせが行われる。

【0021】そして、所定の真空度に到達したら、第二加圧手段7の作動で図2(c)に示す如く上定盤1と下定盤2が更に接近して環状シール4bを圧縮変形させ、それにより両基板A、Bが更に接近して、一方の基板Bに塗布した環状接着剤Cに、他方の基板Aが密接して両者が密閉される。この状態で、位置決め手段8の作動により上定盤1と下定盤2を相対的にXYθ方向へ調整移動させて、両基板A、Bの微合わせが行われる。

【0022】その後、図2(d)に示す如く保持手段3の作動により上定盤1からのみ上方基板Aの吸着を解除して、吸気手段6の作動により閉空間S内に空気を入れてその雰囲気は大気圧に戻す。それにより、両基板A、Bの内外に生じる気圧差で均等に押し潰され、所定のギャップが形成される。

【0023】この際、粗合わせを行う前の時点、具体的には両基板A、Bのセット時に適正量の液晶を適正状態で封入すれば、閉空間S内の雰囲気は大気圧に戻すことにより、両基板A、Bの内外に生じる気圧差で均等に押し潰されて、液晶が封入された状態で所定のギャップ形成が可能となり、後工程で液晶を注入せずに液晶パネルが制作できる。

【0024】それ以降は、閉空間S内が大気圧に戻ったら、第一加圧手段5の作動により上定盤1と下定盤2を離して閉空間Sが開放され、アライメントされた両基板A、Bを取り出して、上述した動作が繰り返される。

【0025】従って、上定盤1及び下定盤2の間のみを密閉状態にしたままその外部でXYθ移動してアライメントできる。その結果、位置決め手段8やその駆動源8bなどが大気中に設置可能となり、通常部品が使用できると共に、真空貫通部品もなくなり、それにより、構造の簡略化が図れ、しかも真空遮断にコストもかかず、粗合わせや微合わせに相当な力を必要としないから、駆動形態の制約が無い。また、真空となる空間を最小にして、その分だけ真空ポンプの容量が小さくすみ、大型の基板でも生産性が高く製造できる。

【0026】更に必要に応じて、前記上定盤1及び下定盤2の対向面のどちらか一方又は両方に、クッション性に優れたXYθ方向への調整移動の際に位置ズレが発生しない緩衝材10を配設した場合には、上定盤1及び下定盤2の片当たりを防止して均一なギャップ形成が容易となる。

【0027】一方、図3及び図4に示すものは、本発明の他の実施例であり、このものは、前記第二加圧手段7

が、移動ブロック4aの上面から上定盤1の周縁部1aへ向けて配設した上下方向へ伸縮自在なシリンドラ7aに代えて、上定盤1の対向面中央に形成された凹部1bを閉塞すると共に上方基板Aを移動不能に保持する上下方向のみ弾性変形可能な可撓性薄板材7bと、この可撓性薄板材7bで閉鎖された凹部1b内の気体を出し入れして微合わせ時に可撓性薄板材7bが下方へ基板Bへ向け膨出するように変形させる加圧部7cとからなる構成が、前記図1及び図2に示した実施例とは異なり、それ以外の構成は図1及び図2に示した実施例と同じものである。

【0028】上記可撓性薄板材7bは、例えばステンレスなどの金属製フィルムなどの上下方向へは弾性変形可能であるがXYθ方向へは変形不能に形成され、その中央には、保持手段3として複数の吸引孔が開穿孔される。上記加圧部7cは、コントローラ（図示せず）で動作制御され、図4(a)に示す上記状態及び図4(b)に示す粗合わせまで、閉鎖凹部1bの内圧が吸気手段6による閉空間Sの内圧と同じになるように空気を出し入れし、粗合わせ後のみ図4(c)に示す如く閉鎖凹部1bの内圧が閉空間Sの内圧より大きくなるように空気を入れる。

【0029】従って、図3及び図4に示すものは、粗合わせ後、図4(c)に示す如く閉鎖凹部1bの内圧上昇により可撓性薄板材7bが膨出変形して、それに保持された上方基板Aを下方基板Bへ更に接近して両者が環状接着剤Cで密閉させることにより、これら両基板A、Bが微合わせ時に最終ギャップ近くまで均等に潰される。その結果、前記図1及び図2に示した実施例よりも剛体製上定盤1及び下定盤2は対向面の平坦度や定盤間の平行精度により基板A、B同士の局所加圧を招き易いが、これら基板A、B同士の局所加圧を完全に防止できて製品が傷付かないという利点がある。

【0030】尚、前示実施例では、上方の加圧板1が、上下方向へ往復動自在な上定盤であり、下方の加圧板2がXYθ方向へ調整移動自在に支持された下定盤である場合を示したが、これに限定されず、これと逆に上定盤をXYθ方向へ調整移動自在に支持し、下定盤を上下方向へ往復動自在に支持しても良い。更に真空雰囲気中でアライメントする場合を示したが、これに限定されず、特殊ガス雰囲気中でアライメントする場合も同様である

【0031】また、基板A、Bの保持手段3、移動シール手段4、第一加圧手段5、吸気手段6、第二加圧手段7及び位置決め手段8は、図示された構造に限定されず、同様に作用すれば他の構造でも良い。特に基板A、Bを移動不能に保持する保持手段3は、吸気手段6による閉空間S内の真空度が低真空であれば、真空差を利用した真空吸着を使用できるが、この真空差を利用できなくなる程度まで閉空間S内が高真空になる場合には、保持手段3として静電チャックや粘着フィルムを使用する

ことにより基板A、Bを移動不能に保持する必要がある。また更に移動シール手段4の駆動真空シール4cに代えて磁性流体式真空シールを使用しても良い。

【0032】

【発明の効果】以上説明したように、本発明のうち請求項1、2記載の発明は、二枚の基板を保持した加圧板が接近移動することにより、相互の周縁部の間を移動シール手段で密閉して閉空間が区画形成されると共に、両基板が所定間隔まで接近し、その後、この閉空間内の空気を抜きながら、両加圧板を相対的にXYθ方向へ調整移動させて、両基板の粗合わせが行われ、所定の真空度に到達してから、上記移動シール手段を変形させて両基板の間が環状接着剤で密閉される位置まで更に接近し、この状態で、上記両加圧板を相対的にXYθ方向へ調整移動させて、両基板の微合わせが行われ、その後、上記加圧板の一方からのみ基板を解放して、上記閉空間内を大気圧に戻すことにより、両基板の内外に生じる気圧差で均等に押し潰されて所定のギャップが形成されるので、両加圧板の間のみを密閉状態にしたままその外部でXYθ移動してアライメントできる。従って、外部から駆動伝達により真空チャンバー内の位置決め手段をXYθ移動してアライメントする従来のものに比べ、位置決め手段やその駆動源などが大気中に設置可能となり、通常部品が使用できると共に、真空貫通部品もなくなり、その結果、構造の簡略化が図れ、しかも真空遮断にコストもかかず、粗合わせや微合わせに相当な力を必要としないから、駆動形態の制約が無い。また、真空となる空間を最小にして、その分だけ真空ポンプの容量が小さくてすみ、大型の基板でも生産性が高く製造できる。

【0033】請求項3、4の発明は、請求項1または2の発明の効果に加えて、粗合わせ後、閉鎖凹部の内圧上昇により可撓性薄板材が膨出変形して、それに保持された一方基板を他方基板へ更に接近して両者が環状接着剤Cで密閉させることにより、これら両基板が微合わせ時に最終ギャップ近くまで均等に潰されるので、剛体製加圧板の平坦度や平行精度に関係なく基板同士の局所加圧を防止する。従って、剛体製の加圧板は対向面の平坦度や定盤間の平行精度により基板同士の局所加圧を招き易いが、これら基板同士の局所加圧を完全に防止できて製品が傷付かない。

【0034】請求項5の発明は、請求項2または4の発明の効果に加えて、閉空間内の雰囲気は大気圧に戻すことにより、両基板の内外に生じる気圧差で均等に押し潰されて、液晶が封入された状態で所定のギャップ形成が可能となるので、後工程で液晶を注入せずに液晶パネルを制作できる。

【図面の簡単な説明】

【図1】 本発明の一実施例を示す液晶パネル用基板の貼り合わせ装置の縦断正面図である。

【図2】 (a)～(d)は液晶パネルの製造方法を工



程順に示す説明図である。

【図3】 本発明の他の実施例を示す液晶パネル用基板の貼り合わせ装置の縦断正面図である。

【図4】 (a)～(d)は液晶パネルの製造方法を工程順に示す説明図である。

【図5】 従来の液晶パネル用基板の貼り合わせ装置の一例を示す縦断正面図である。

【符号の説明】

A, B 基板

C 環状接着剤

S 閉空間

1 加圧板(上定

盤)

1 a 周縁部

1 b 凹部

2 加圧板(下定盤)

2 a 周縁部

3 保持手段

4 移動シール手段

5 第一加圧手段

6 吸気手段

7 第二加圧手段

7 b 可撓性薄板

材

7 c 加圧部

8 位置決め手段

【図1】

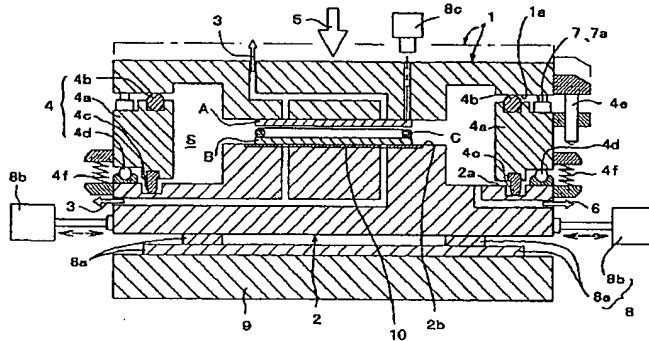

【図2】

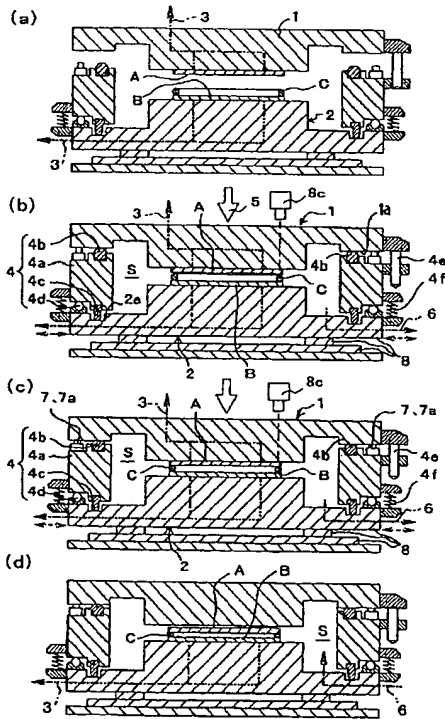

【図4】

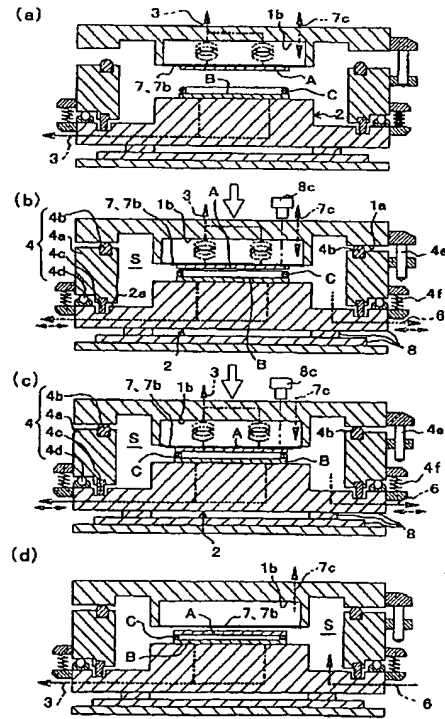

【図3】

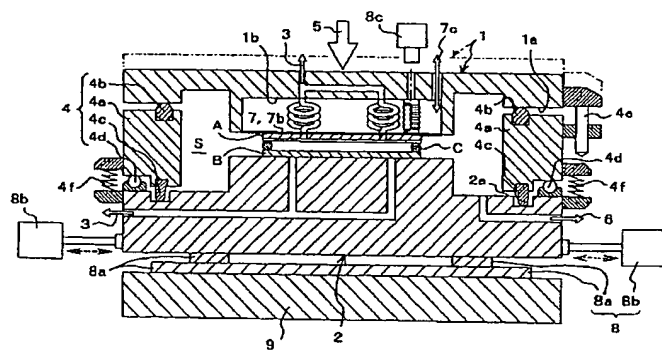

【図5】

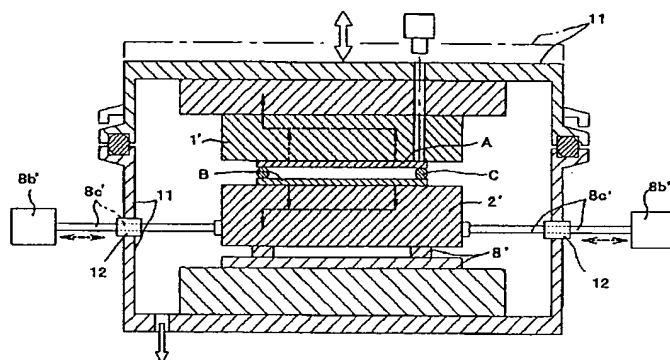

フロントページの続き

Fターム(参考) 2H088 EA02 FA04 FA10 FA16 FA17  
FA20 FA30 MA20  
2H089 NA38 NA49 NA60 QA12 QA14  
5G435 AA17 BB12 KK05 KK10